

R A D I O N I C S

OmegaPass Access Control Systems

8112:Access, 8112:Assign, and 8112:Cards

Program Entry Guide

For the D8112A Control/Communicator

Notice: The material and instructions covered in this manual have been carefully checked for accuracy and are presumed to be reliable. However, Radionics, Inc. assumes no responsibility for inaccuracies and reserves the right to modify and revise this manual without notice.

It is our goal at Radionics to always supply accurate and reliable documentation. If a discrepancy is found in this documentation, please mail a photocopy of the corrected material to:

Radionics, Inc.
 Technical Writing Department
 1800 Abbott Street
 Salinas, CA 93901

TABLE OF CONTENTS

Page

Introduction	2
Part I. The 8112:Access Product Handler Program	4
1. Getting Around in the 8112:Access Product Handler Program	4
2. Naming an 8112:Access File	5
3. Saving the 8112:Access File	5
4. Loading the 8112:Access File	5
5. Copying the 8112:Access File	6
6. Programming Doors	6
6.1 Entering the Door Programming Module	6
6.2 The Door Module Program Entry Guide	7
7. Programming Authorization Levels	11
7.1 Entering the Level Programming Module	11
7.2 The Level Module Program Entry Guide	12
Part II. The 8112:Assign and 8112:Cards Product Handler Programs	
8. Introduction to 8112:Assign and 8112:Cards	14
9. 8112:Assign and 8112:Cards Product Handler Structure	14
9.1 Naming 8112:Assign and 8112:Cards Files	15
9.2 Saving 8112:Assign and 8112:Cards Files	15
9.3 Loading 8112:Assign and 8112:Cards Files	15
9.4 Copying and Reviewing 8112:Assign and 8112:Cards Files	16
9.5 Selecting Group and User Numbers	17
10. The 8112:Assign Program Entry Guide	18
10.1 Getting Around in the 8112:Assign Product Handler Program	18
10.2 The Program Items of the 8112:Assign Product Handler Program	19
11. The 8112:Cards Program Entry Guide	20
11.1 Getting Around in the 8112:Cards Product Handler Program	20
11.2 The Program Items of the 8112:Cards Product Handler Program	21

Notice of D8112A Software Changes and Programming Manual Revisions

Three versions of D8112A software, and four revisions of this programming manual have been produced. Each version of software has unique operational characteristics which are summarized below. If you do not know which version of software you are working with, use Command 59 to determine the software version in the panel.

500/100 (Cmd 59 displays: 50/10, Manual rev A): This software was recalled, and new software was distributed for a field retrofit.

501/101 (Cmd 59 displays 51/11, Manual rev B): This software changed the door re-locking timing sequence, and did not operate Hold Open Door Skeds reliably. (See document #73-05458-000)

700/700 (Cmd 59 displays 70/70, Manual rev C & rev D): This software changed the door re-locking timing sequence back to the original sequence used in 500/100. It operates Hold Open Door Skeds properly, and it has enhanced features available in Command 51 which allow the user to manually hold open doors, and provides for cycle testing of the doors. This version of software requires the use of the SkedInit Product Handler Program to reset certain Sked-operated functions, which in prior versions of the D8112A were reset each time the panel was reset (disable/restart, or ResetBye).

Introduction

The OmegaPass integrated access control and security system consists of the D8112A Control/Communicator, installed in combination with relay output and card reader accessories.

The D8112A Control Communicator is programmed using the D9300 Remote Account Manager or the D5100 Bar Code Programmer. A number of "product handler program files" describe the operation of the D8112A and how it responds to alarm sensor and card reader inputs. The D8112A connects directly to standard "dial-up" telephone lines and contains an internal "auto-answer modem" for communicating with the Remote Account Manager. The D8112A can automatically call a central station alarm receiver and transmit alarm and supervisory messages.

Up to four different doors can be controlled by one D8112A. Each reader has a "door address" (A, B, C, or D) which corresponds to one set of two relays (used to operate an electric doorstrike, and an optional indicating device). When a valid card is presented at a card reader which controls a specific door, the doorstrike and indicator (buzzer) relays are operated according to the program for that door.

Each door is programmed separately and can latch open the doorstrike for up to 15 seconds. The D8112A can be programmed to sound a buzzer or light an indicator for up to 15 seconds after the doorstrike is activated. Up to two minutes of alarm zone shunting can be programmed. The strike automatically relocks, and the buzzer silences, when the door is opened (or when the timers expire, whichever is shorter). Shunts are removed when the door is closed (or when the timers expire, whichever is shorter). Up to the last 60 seconds of the shunt time can be with a warning buzzer or light to indicate that the shunt is about to be removed.

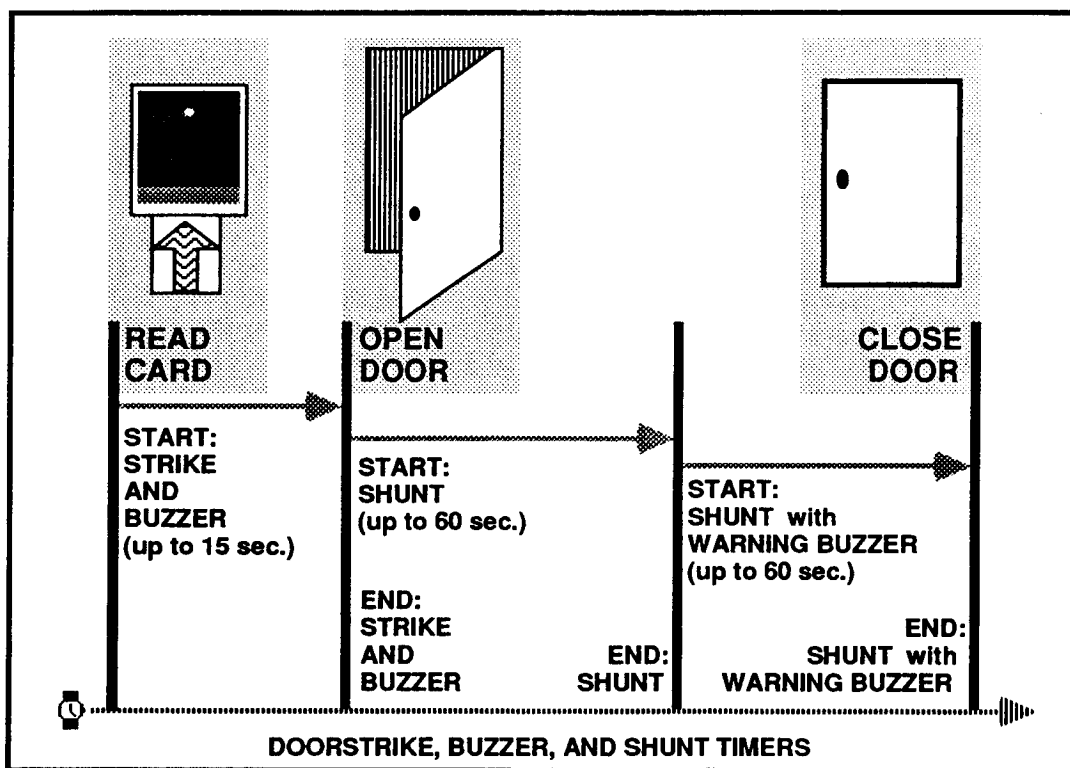

In the D8112A Access Control System, two relays are dedicated to each door in the system. One relay controls the doorstrike and a second relay is optionally used to connect to a buzzer, light, or an annunciator in a guard station if necessary. The doorstrike and optional indicator connections to the D8129 OctoRelay Module should be located inside the same enclosure as the D8112A. The D8129 OctoRelay Module contains eight form "C" relays.

The D8210 Wiegand Interface connects to two separate doors (*either* A and B - *or* - C and D) and has two relays for each of the doors (four relays total: two for doorstrikes, two for optional indicators). Two D8210 interfaces can be connected to the D8112A. (A D8129 OctoRelay is not required when using the D8210.)

Up to 255 access card Users can be programmed into the D8112A. Each User can be assigned one of seven different authorization levels for each of the four doors in the system. When a card is read the authorization level allows or denies entry based on the armed state of the D8112A. Authorization levels can be programmed to automatically disarm the system, transmit an opening report to the central station along with an ID code, and/or log the event and ID code in the D8112A's memory. The authorization level can be programmed to disarm the entire system, or to change the armed state of the system from master to perimeter armed.

The D8112A can be programmed so that events are logged in the memory of the D8112A as they occur. (Up to 400 events can be stored before they are erased, oldest event first.) These events can be easily retrieved using the Remote Account Manager, then compiled into informative reports for the alarm company and/or the end-user. The D8131 Printer/CRT Interface can be connected to the D8112A to provide an output to a serial printer (C4001P, for example) or CRT terminal for on-premises recording of system events (D8135 printer cable sold separately). If the D8131 is used in conjunction with a D128 Dual Phone Line Switcher, the D8134 Ribbon Cable is required. Optionally, a D8150 Local Security Printer can be connected directly to the D8112A for on-premises recording of system events (D8134 Ribbon Cable required, sold separately).

Access control features are programmed into the D8112A using the 8112:Access, 8112:Assign, and 8112:Cards Product Handler Programs. Alarm responses, reporting formats, Command Center features, and other security features are programmed in the 8112:MAIN and 8112:AUX Product Handler Programs.

The 8112:Access, 8112:Assign, and 8112:Cards files only work when loaded into an Omegalarm D8112A Control/Communicator which contains a CPU board designed specifically for Access Control systems using special operating system software.

In addition to Access Control, the D8112A can be programmed with 8112:Skeds files. Using 8112:Skeds, up to 64 individual scheduled events or "Skeds" can be programmed into each D8112A. Each Sked can disable opening or closing reports, control relays, or disable an arm/disarm combination. Skeds is also used to enable/disable access control system authorization levels, change the way the control panel logs events, and hold doors open at specified times. See the *Omegalarm 8112:Skeds Program Entry Guide* for details.

8112:Access, 8112:Assign, and 8112:Cards files are written using either the Omegalarm D5100 Bar Code Programmer, or the D9300 Remote Account Manager. This manual focuses on programming using the D5100 programmer. The D5100 must contain the OmegaWand 2.1 operating system and 32K RAM capacity so that it can store the programs used for access control systems. Before programming the D8112A, the technician should be familiar with the following Radionics products:

D8112A Control/Communicator	D8114 Quad Serial Output Module
D5100 Bar Code Programmer	D8220 Insert Card Reader and/or
8112:MAIN Product Handler Program	D8225 Proximity Card Reader System and/or
8112:AUX Product Handler Program	D8210 Wiegand Interface Module
8112:Assign Product Handler Program	D8129 OctoRelay Module
8112:Cards Product Handler Program	D8131 Printer/CRT Interface Module or
8112:Access Product Handler Program	D8150 Local Printer
8112:Skeds Product Handler Program	
SkedInit Product Handler Program (for D8112A rev 600/600 and higher)	

NOTICE: DO NOT LOAD 8112:Comex OR 8112:PText INTO THE D8112A. If either of these programs are loaded into the D8112A, the control/communicator stops operating (CPU failure). The D8112A must then be loaded with all NEW FILES, then reprogrammed.

Product Handler Program Version Numbers: The Product Handler Title which appears in the D5100 Bar Code Programmer's display includes the "version number" of the product handler. For example, the title of 8112:MAIN appears as *..8112 MAIN A7..* in the programmer's display. In this example, *A7* is the *version* number. In this manual, Product Handler titles are shown with a "generic" version number *.x#*, instead of the actual letter and number. For example, the title of 8112:Access appears as *..8112Access.A1.* in the programmer's display. In this manual, the title of 8112:Access is shown as *..8112Access.x#...* [Future versions of product handlers will be identified by a 4-digit code in the title (i.e.: *01.00*) instead of a letter and number combination.]

I. The 8112:Access Product Handler Program

The 8112:Access Product Handler Program is made up of two programming modules—**Door** and **Level**:

In the Door module you program the D8112A to automatically shunt zones, to operate a buzzer on a card reader, and to control doorstrikes and other accessories connected to the Omegalarm D8129 OctoRelay Module (or D8210 Wiegand Interface)— all based on the data received from the access control card readers.

In the Level module you program the responses of the D8112A and the D8129 (or D8210 Wiegand Interface), based on the authorization level of the card which was read, and on the armed state of the panel.

1. Getting Around in the 8112:Access Product Handler Program

1. ADVANCE the programmer's display to `..8112Access.x#..` . Scan the **ENTER** bar code.
2. When the display shows `8112X: New File` scan the **ENTER** bar code.
3. The display now shows `8112X:` . The blank space is provided for a file title. If you plan on saving this file, see section "2. Naming an 8112:Access File." If you don't wish to save the file scan the **ENTER** or the **ADVANCE** bar code to skip over the file title.
4. The display now shows `1 Door A`. This is the first item of the 8112:Access program. To continue programming, see sections 6 and 7 which explain the Door and Level Modules. Figure 1 is an overview showing how to access various program items in the 8112:Access Product Handler Program.

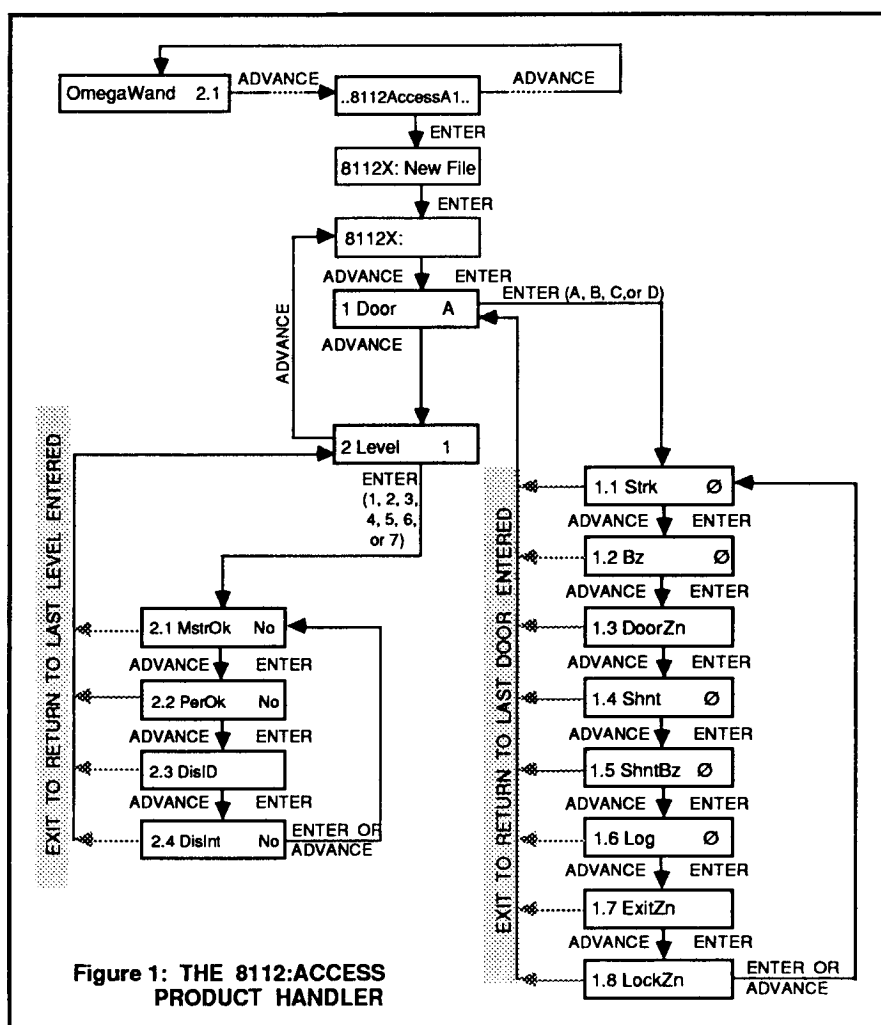

2. Naming an 8112:Access File

An 8112:Access file cannot be saved to the programmer's memory without a file title. To construct an 8112:Access file title, advance the programmer's display to *8112X:* . The blank space is provided for a title. Each new file created needs to have a file title different from any other 8112:Access file stored in the programmer. The title can be from one to nine characters in length. The characters can be any of the letters, characters, numbers or punctuation marks shown on the D5100 Programmer cover. Once the title is complete, scan the **ENTER** bar code. The Programmer display advances to *1 Door A* . The file can now be saved, edited or loaded into the D8112A.

3. Saving the 8112:Access File

The number of files that the D5100 Programmer can save to memory depends on the available memory in the programmer. This memory is used to save all types of files, including 8112:MAIN, 8112:AUX, 8112:Skeds, 8112:Cards, 8112:Assign, and 8112:Access files. The total number of files which can be saved is divided among these product handler files.

1. After you are finished programming the 8112:Access file, scan the **SAVE FILE** bar code. If you gave the file a title when you began programming, the file is saved immediately.
2. If the display shows *8112X:* , then the file does not have a title. Construct a file title, scan the **ENTER** bar code and then scan the **SAVE FILE** bar code again.
3. If the display shows *Check Title* , then there is already an 8112:Access file using that title. Either change the file title and repeat step 1, or scan the **REPLACE FILE** bar code. This erases the file stored in memory and saves the new file.

4. Loading the 8112:Access File

The 8112:Access program works in conjunction with 8112:Assign and 8112:Cards to provide access control system programming for the D8112A. These programs are functional only when loaded into a D8112A Control/Communicator containing appropriate 8112:MAIN and 8112:AUX programs.

- "8112:MAIN" is used to determine the basic operating characteristics of the D8112. (See the *Omegalarm 8112:MAIN Program Entry Guide*.)
- "8112:AUX" contains several optional programs for the D8112. Two features for access control systems can be enabled in the Cmd5's subhandler program of 8112:AUX. Command 51 enables access door tests and manual control of access doors (Hold Open Door). Command 53 enables setup functions using the Alpha II Command Center. (See the *Omegalarm 8112:AUX Program Entry Guide* for further details.)

Loading the File:

1. Connect the programmer to the control/communicator.
2. Advance to programmer display until *..8112Access.x#.* is showing. Scan the **ENTER** bar code. The display changes to *8112X: New File* .
3. Momentarily connect the D8112's restart terminal (32) to a common terminal (29).
4. Scan the **ADVANCE** bar code until the correct 8112:Access file title is displayed by the programmer. Scan the **ENTER** bar code. If the file requires editing, do so now.
5. When the file is edited and ready to load, scan the **LOAD PANEL** bar code. The programmer's display momentarily shows *Loading 8112* , then returns to the first program item in the file.

5. Copying the 8112:Access File

1. Connect the D5100 Bar Code Programmer to the control/communicator.
2. Advance the programmer's display until *..8112Access.x#..* is showing. Scan the ENTER bar code. The display changes to *8112X: New File*.
3. Momentarily connect the D8112's restart terminal (32) to a common terminal (29).
4. Scan the COPY PANEL bar code. The display momentarily shows *Copying 8112* and then changes to *8112X:*. The 8112:Access file has been copied. Scan the ADVANCE bar code to view the file. You may now edit the file and re-load it into the D8112, or save the file for future use.

6. Programming Doors

The first program item in the 8112:Access Product Handler Program is *1 Door A*. This prompt is the access point to the Door programming module. The Door module is used to set the responses to valid cards read by a card reader which has been set with a door address (A, B, C, or D). (For more information about door addresses, see the *D8210, D8220, or D8225 Operation and Installation Manual*.) All four doors are programmed and saved in a single 8112:Access file, however, the data for each door is programmed in a separate Door module (see step 4).

6.1 Entering the Door Programming Module

1. To select the door, advance the programmer's display to *1 Door A*.
2. Scan the appropriate door address (A, B, C, or D). The display changes to show the door you are programming. (For example, if you scan "B" the display shows *1 Door B*.)
3. Scan the ENTER bar code. The display changes to *1.1 Strk Ø*. You have now entered the Door module and can begin programming the characteristics of the selected door. (See section 6.2 for program item descriptions.)
4. After programming the last item (1.8 LockZn), scan the ENTER bar code. The D5100's display shows the prompt *1.1 Strk*.

To program another door address, scan the EXIT bar code to return to the *1 Door* prompt. Scan the appropriate door address (A, B, C, or D), then scan the ENTER bar code. The display changes to *1.1 Strk Ø*. You have once again entered the Door module and may program the characteristics of the selected door.

NOTE: Scanning the EXIT bar code while the programmer is displaying any program item in the Door program module returns the display to the *1 Door* prompt.

5. When you have finished programming each of the door addresses (A, B, C, D) that you are going to use, scan the EXIT bar code. The *1 Door* prompt appears in the display. Scan the ADVANCE bar code to bring the *2 Level* prompt into the display. (See *Section 7. Programming Authorization Levels*, for details on programming the Level module.)

6.2 The Door Module Program Entry Guide

This section describes the program items of the Door program module. Each program item is listed with the program item prompt, default setting, entry selections available to that program item, and a description of the function of the program item.

Prompt & Default	Selections	Description
1 Door A	A, B, C, or D	This is the access point for the Door Module. Select the door address to be edited or reviewed (A, B, C, or D).
1.1 Strk Ø	Ø thru 15	Enter the number of seconds the doorStrike will be activated by the D8129 or D8210. Enter up to 15 seconds. Radionics recommends a minimum of 10 seconds of strike time. A "Ø" entry disables the rest of the items programmed for this Door.
1.2 Bz Ø	Ø thru 15	Enter the number of seconds the Buzzer (optional indicator) relay energizes when the doorstrike is activated. This amount should be less than or equal to the time programmed for item 1.1 Strk.

Items 1.1 Strk and 1.2 Bz are used to program the amount of time the relays on the D8129 (or D8210) and the buzzer on the D8220 card reader (or optional indicator relay) are activated for the door after a valid card has been read (see Table 1).

The buzzer and strike are both deactivated when the zone programmed in item 1.3 DoorZn is faulted (i.e. when the door is opened) or when the strike time (1.1 Strk) expires. If a contact (or other detection device) is not installed on the door, the buzzer and doorstrike remain activated for the times programmed.

Table 1: DOOR ADDRESS RELAY CONTROL

DOOR ADDRESS	A		B		C		D	
D8129 RELAY #	1	2	3	4	5	6	7	8
D8210 RELAY #	1	2	3	4	1	2	3	4
FUNCTION	STRIKE	BUZZER	STRIKE	BUZZER	STRIKE	BUZZER	STRIKE	BUZZER

For access control applications, the D8129 OctoRelay needs to be programmed (via switch settings) for the "Remote Control Mode." When a door address has been programmed, you will not be able to operate the relays associated with that door address using Command 54. The example in Table 2 illustrates the Command 54 Alpha II Command center display in an access control application where doors A and B are programmed. In the Alpha II display, relays controlled by the access control system are shown as "X" in the display.

Table 2: ALPHA II DISPLAY FOR RELAY CONTROL

DOOR ADDRESS	A		B		C		D		
D8129 RELAY #	1	2	3	4	5	6	7	8	
ALPHA II DISPLAY FOR COMMAND 54 (DOORS A & B ARE ENABLED)	RELAYS	X	X	X	X	5	6	7	8
D8210 RELAY #	1	2	3	4	1	2	3	4	

1.3 DoorZn

blank or 1 thru 8

.Enter the number of the zone to be shunted when this doorstrike is activated. When this DoorZone is faulted the doorstrike re-latches, the Buzzer stops, and the shunt timer in program item 1.4 Shnt is activated. (See Sked Note for alternate operation.)

Typically, an alarm contact is installed on the door controlled by the card reader. 1.3 DoorZn assigns the door address to a master zone of the D8112A. If no detection device is installed on the door, this program item should be left blank.

Do NOT program two different doors for the same Door Zone.

Sked Note: When a "Hold Open Door" Sked activates the door relay, the zone assigned is shunted and the doorstrike is activated until the "Hold Open Door Sked" is removed. Hold Open Door Skeds are removed using "Normal Door Operation" Skeds, or Command 51 (Command 51 doorstrike control is available with D8112A software version 600/600 and higher). Normal Door Operation Skeds and Command 51 remove all zone shunts associated with the door, no matter how the shunts were activated. For example: If the specified door is open and the zone is shunted by a card read or exit button, then a Normal Door Operation Sked runs, an alarm is generated (if the zone is armed).

1.4 Shnt Ø

Ø thru 15

Enter the amount of time the zone is to remain Shunted after the zone programmed in 1.3 DoorZn is faulted. Shunt time begins when the Door Zone is faulted, and ends when the zone is restored. These entries are made in 4 second increments. Use the table below to determine the proper entry:

Ø = Øseconds		
1 = 4 seconds	6 = 24 seconds	11 = 44 seconds
2 = 8 seconds	7 = 28 seconds	12 = 48 seconds
3 = 12 seconds	8 = 32 seconds	13 = 52 seconds
4 = 16 seconds	9 = 36 seconds	14 = 56 seconds
5 = 20 seconds	10 = 40 seconds	15 = 60 seconds

If the Door Zone is faulted after the shunt time expires, the panel begins the protective zone response as programmed in 8112:MAIN zone codes (ie: entry delay, instant alarm, etc. See Figure 2). Additional shunt time, combined with buzzer activation can be programmed in item 1.5 ShntBz.

1.5 ShntBz Ø

Ø thru 15

Enter the amount of additional time the zone is to be shunted while the buzzer on the card reader (and buzzer relay) is activated. This entry is made in 4 second increments. Use the table in item 1.4 Shnt to determine the proper entry.

The buzzer combined with additional shunt time serves as a reminder to the user to close the door before the shunt time expires. For example: to provide a total of one minute of shunt time with a 40 second warning buzzer, enter "5" (20 seconds) in 1.4 Shnt, and "10" (40 seconds) in 1.5 ShntBz.

1.7 ExitZn

blank or 1 thru 8

Enter the number of the zone which is connected to an exit button or motion detector.

When this zone faults, the doorstrike, buzzer, and shunt are activated as programmed in items *1.1 Strk*, *1.2 Bz*, *1.3 DoorZn*, *1.4 Shunt*, and *1.5 ShntBz*.

1.7 ExitZn is the zone which is faulted when a pushbutton, motion detector, or other initiating device is triggered to allow exiting from the associated door address. When this zone is faulted, the D8112A shunts the Door Zone and activates the doorstrike relay. Exits using this method are logged as user "ØØØ".

Recommended Zone Codes for zones used in *1.7 ExitZn* are:

- 1515 This zone code provides a 24-hour, silent, invisible, non-reporting zone. This zone code cannot be used if you are using silent alarm output in the system.
- 1715 This zone code provides a controlled, silent, invisible, non-reporting zone. This zone code does not affect silent alarm output. Use only exit buttons or motion detectors with normally open contacts.

Do NOT program any Exit Zone for the same zone as in item *1.3 DoorZn*.

Do NOT program two different doors for the same Exit Zone.

1.8 LockZn

blank or 1 thru 8

Enter the number of the zone which **MUST** be in a normal condition in order for the doorstrike to operate. (Interlock zone)

Typical applications for use of the Lock Zone are vestibule control, man-traps, vaults, and counting rooms. *1.8 LockZn* is the zone which needs to be in a normal condition before the doorstrike relay is activated. If this zone is faulted when a card is read, access is denied, regardless of the authorization level of the card or the armed state of the panel. *Denials resulting from a faulted Lock Zone (interlock) are not logged.*

7. Programming Authorization Levels

The prompt *2 Level 1* is the access point to the Level programming module. The Level module is used to set the responses of the D8112A for each of the seven (7) authorization levels of access control cards under various arming conditions of the panel. All seven authorization levels are programmed and saved in a single 8112:Access file, however, the data for each authorization level is programmed in a separate Level module (see step 4). User's cards are assigned authorization levels for each door in the Access Control system using the 8112:Assign Product Handler Program.

7.1 Entering the Level Programming Module

- 1) To select the level to edit, ADVANCE the programmer's display to *2 Level 1*. This is the entry point for the Level programming module.
- 2) Scan the appropriate Level number (1 through 7). The programmer's display changes to show the level you are programming. (For example, if you scan "2" the display shows *2 Level 2*.)
- 3) Scan the ENTER bar code. The display changes to *2.1 MstrOK*. You have now entered the Level module and can begin programming the characteristics of the selected authorization level. (See section 7.2 for program item descriptions.)
- 4) After programming the last item (2.4 DisInt), scan the ENTER bar code. The D5100 displays the prompt *2.1 MstrOK*.

To program another authorization level, scan the EXIT bar code to return to the *2 Level* prompt. Scan the number for the next level you want to edit, then scan the ENTER bar code. The display changes to *2.1 MstrOK*. You have once again entered the Level module and may program the characteristics of the selected level.

NOTE: Scanning the EXIT bar code while the programmer is displaying any program item in the Level program module returns the display to the *2 Level* prompt.

- 5) When you have finished programming all the levels in the system, scan the EXIT bar code. The *2 Level* prompt appears in the display. Scan the ADVANCE bar code to bring the *1 Door* prompt into the display or scan the EXIT bar code to return to the 8112:Access title prompt. You may now save the file or load it directly into the D8112A.

7.2 The Level Module Program Entry Guide

This section describes the program items of the Level module. Each program item is listed with the program item prompt, default setting as it appears in the programmer's display, entry selections available to that program item, and a description of the function of the program item.

Prompt & Default	Selections	Description
2 Level 1	1 thru 7	<p>This is the access point for the Level Module. Select the authorization level to be edited or reviewed. Level modules for levels one through seven (1 - 7) are entered from this program item.</p> <p>Access control authorization Levels can be controlled (turned on and off) using the 8112:Skeds program and/or the Alpha II Command Center (Command 53, Function C). If it appears that a programmed Level is not working, use Command 53 to check the status of the Level.</p>
2.1 MstrOK No	Yes or No	<p>Allow access to Users with cards programmed for this Level while the D8112A is Master Armed.</p> <p>If programmed Yes, cards programmed with this authorization Level will allow access if the panel is Master Armed or completely disarmed.</p> <p>If programmed No, cards programmed with this authorization Level will be denied access if the panel is Master Armed. Access is granted if the panel is completely disarmed.</p>
2.2 PerOK No	Yes or No	<p>Allow access to Users with cards programmed for this Level while the D8112A is Perimeter Armed.</p> <p>If programmed Yes, cards programmed with this authorization Level will allow access if the panel is Perimeter Armed or completely disarmed.</p> <p>If programmed No, cards programmed with this authorization Level will be denied access if the panel is Perimeter Armed. Access is granted if the panel is completely disarmed.</p>
2.3 DisID	Blank, Ø thru 9 or B thru F	<p>Disarm the D8112A when a card programmed for this Level is read, and identify the opening by this ID code. If this item is blank, this authorization level will <u>not</u> disarm the panel. 8112:MAIN program item 54 Comb ID must be programmed Yes. If 8112:MAIN program item 50 ReO/C is programmed Yes it will affect the way that openings by access cards are reported and logged. All cards programmed for this Level will be identified by the same ID code.</p>

Central Station Reports: The opening is transmitted to the central station with this Combination ID (if the D8112A is programmed for opening reports).

Local Logging: The opening is recorded in the D8112A's memory including the ID code for this Level (MLog must be enabled in 8112:AUX). The User Number for the card is recorded separately.

NOTE: This program item will "Master" disarm the system if item 2.4 is programmed No. If item 2.4 is programmed Yes, only the interior zones will be disarmed.

IMPORTANT: Cards cannot be used at a card reader to silence an alarm bell. An arm/disarm combination must be manually entered at the Command Center to silence the alarm.

2.4 DisInt No

Yes or No Disarm only the interior zones when this level card is read. A user ID code needs to be entered in item **2.3 DisID**.

This program item is used to restrict this authorization level to disarming only the interior zones, or allow this level to disarm the entire panel. To disarm any part of the system, an ID code must be entered in item **2.3 DisID**.

When programmed "YES", ONLY the interior zones are disarmed. (Perimeter zones remain armed.)

When programmed "NO", the entire system will be disarmed.

Table 3 shows the changes in armed state which occur when a valid card is read under various armed states.

Table 3: DISARMING INTERIOR ZONES

D8112A ARMED STATE BEFORE CARD IS READ	MASTER ARMED		PERIMETER ARMED w/DELAY		PERIMETER ARMED INSTANT		READY TO ARM (DISARMED)	
	YES	NO	YES	NO	YES	NO	YES	NO
D8112A ARMED STATE AFTER CARD IS READ	PERIMETER ARMED w/DELAY	READY TO ARM (disarmed)	PERIMETER ARMED w/DELAY	READY TO ARM (disarmed)	PERIMETER ARMED w/DELAY	READY TO ARM (disarmed)	READY TO ARM (disarmed)	READY TO ARM (disarmed)

OPERATION NOTES:

Exit Delay: During exit delay the *DisID* and *DisInt* features are disabled. If a card is read during exit delay, it WILL NOT disarm the system, but it WILL activate the doorstrike, shunts, and buzzers. "Exit Zone" egress is allowed during exit delay. (See program item **1.7 ExitZn**.)

Entry Delay: When a card programmed to disarm the interior is read, the Command Center display shows "Perimeter Delay" even if the Door Zone is programmed INSTANT.

If a Door Zone has been force armed or selective zone shunted, and a card programmed to disarm the interior is read, the Command Center displays "Perimeter Partial".

Swinger Shunt: If a Door Zone programmed for swinger shunt has been force armed, and a card programmed to disarm the interior is subsequently read, an ALARM is generated from that zone.

Faulted Zone: If the system is armed and a zone has reported an alarm, and the zone is still faulted when a card programmed to disarm the interior is read, another ALARM is generated from that zone.

Skeds/Logger: A card programmed to disarm the system disarms the system and logs the opening even when a "Hold Open Door" Sked is operating.

Part II. The 8112:Assign and 8112:Cards Product Handler Programs

CONTENTS	Page
8. Introduction to 8112:Assign and 8112:Cards	14
9. 8112:Assign and 8112:Cards Product Handler Structure	14
9.1 Naming 8112:Assign and 8112:Cards Files	15
9.2 Saving 8112:Assign and 8112:Cards Files	15
9.3 Loading 8112:Assign and 8112:Cards Files	15
9.4 Copying and Reviewing 8112:Assign and 8112:Cards Files	16
9.5 Selecting Group and User Numbers for 8112:Assign and 8112:Cards	17
10. The 8112:Assign Program Entry Guide	18
10.1 Getting Around in the 8112:Assign Product Handler Program	18
10.2 The Program Items of the 8112:Assign Product Handler Program	19
11. The 8112:Cards Program Entry Guide	20
11.1 Getting Around in the 8112:Cards Product Handler Program	20
11.2 The Program Items of the 8112:Cards Product Handler Program	21

8. Introduction to 8112:Assign and 8112:Cards

The Omegalarm 8112:Assign Product Handler Program is used to assign authorization levels* for Users of access control cards. Each User can be assigned an appropriate authorization level for doors* (A, B, C, and D) in the access control system. The User can be assigned a *different* authorization level for each door in the access control system if needed for the application.

The 8112:Cards Product Handler Program is used to program the D8112A to identify the serial number in each D8230-25, D8240-25, and D8235-10 Card as a "User" number.

The 8112:Assign and 8112:Cards files only work when loaded into an Omegalarm D8112A Control/Communicator which contains the 8112:Access Product Handler Program and a CPU board designed specifically for Access Control systems using special operating system software.

* The operating characteristics of the doors and the parameters for the seven authorization levels are programmed in the 8112:Access Product Handler Program.

9. 8112:Assign and 8112:Cards Product Handler Structure

The 8112:Assign and the 8112:Cards Product Handler Programs are very similar in structure. Files written with these product handlers are named, saved, loaded, and copied from the panel using the same basic steps. Each 8112:Assign file and each 8112:Cards file contains a "Group" of 32 "Users". The steps for selecting the "Group" number for each of the files are the same in both of the product handlers. These steps are described in sections 9.1 through 9.5.

Each group of Users is programmed and loaded into the D8112A using a separate file. Up to 255 Users can be programmed with authorization levels when all eight groups are loaded into the D8112A.

9.1 Naming 8112:Assign and 8112:Cards Files

Product Handler program files cannot be saved to the programmer's memory without a file title. The file title is used to identify the file for later editing and use. Each new file created needs to have a file title different from any other file stored in the programmer for a specific product handler. The title can be from one to nine characters in length. The characters can be any of the letters, characters, numbers, or punctuation marks shown on the D5100 Programmer cover.

1. ADVANCE the programmer's display to the product handler's title (*..8112Assign.x#..* or *..8112Cards.x#..*). Scan the **ENTER** bar code.
2. When the display shows the "New File" prompt (*8112S: New File* or *8112C: New File*), scan the **ENTER** bar code.
3. The display now shows the title prompt for the product handler: *8112S:* for 8112:Assign, or *8112C:* for 8112:Cards. The blank space is provided for a file title. Scan up to nine of the characters shown on the D5100 programmer's cover to give the file a name that will help you remember how it is programmed.
4. Scan the **ENTER** bar code. The Programmer display advances to *Group 1*. This is the first item of the 8112:Assign and the 8112:Cards programs. The file can now be saved, edited, or loaded into the D8112A. To begin editing the program, see section 9.5.

9.2. Saving 8112:Assign and 8112:Cards Files

The number of files that the D5100 Programmer can save to memory depends on the unused RAM capacity of the programmer. This memory is used to save all types of product handlers and program files. The total number of files which can be saved is divided among the program files and product handlers.

Remember: Each Group of Users is programmed in a separate file. The Group number should not be changed after Users have been entered in the file. The file cannot be saved if you change the Group number. This applies to both product handlers.

1. After you are finished programming the product handler file, scan the **SAVE FILE** bar code. If you gave the file a title when you began programming, the file is saved immediately.
2. If the display shows the title prompt: *8112S:* (for 8112:Assign) or *8112C:* (for 8112:Cards), then the file does not have a title. Construct a file title, and then scan the **SAVE FILE** bar code again.
3. If the display shows *Check Title*, then there is already a file for the product handler using that title. Either change the file title and then scan the **SAVE FILE** bar code again, or scan the **REPLACE FILE** bar code. **REPLACE FILE** erases the file stored in the programmer's memory and saves the new file.

9.3 Loading 8112:Assign and 8112:Cards Files

The 8112:Assign and 8112:Cards programs work in conjunction with 8112:Access to provide access control system programming for the D8112A. These programs are functional only when loaded into a D8112A Control/Communicator containing appropriate 8112:MAIN and 8112:AUX programs. "8112:MAIN" is used to determine the basic operating characteristics of the D8112. (See the *Omegalarm 8112:MAIN Program Entry Guide*.) "8112:AUX" contains several optional programs for the D8112. (See the *Omegalarm 8112:AUX Program Entry Guide*.)

Loading the File:

1. Connect the programmer to the control/communicator.
2. Advance the programmer's display until the product handler's name appears (*..8112Assign.x#..* or *..8112Cards.x#..*). Scan the **ENTER** bar code. The display changes to the "New File" prompt. Momentarily connect the D8112's restart terminal (32) to a common terminal (29).
3. Scan the **ADVANCE** bar code until the correct file title is displayed by the programmer. Scan the **ENTER** bar code. If the file requires editing, do so now. **DO NOT CHANGE THE GROUP NUMBER.**

Remember: Each file loaded into the panel needs to be a different Group number. If you load two files for the same product handler containing the same Group number, the first file will be overwritten by the second file. DO NOT CHANGE THE GROUP NUMBER after parameters have been entered into the file.

4. When the file is edited and ready to load, scan the **LOAD PANEL** bar code. The programmer's display momentarily shows *Loading 8112*, then returns to the first program item prompt in the file.
5. If you need to load more files for the product handler, **EXIT** the file then repeat steps 3 through 5 for each file you want to load into the panel.

9.4 Copying and Reviewing 8112:Assign and 8112:Cards Files

When updating an existing D8112A Access Control System, you should always **copy** and **review** the existing files from the D8112A, then edit and reload them. The D5100 Bar Code Programmer is used to copy files from the D8112A. Only one Group of Users can be copied from the panel at a time.

Copying the File:

1. Connect the D5100 Bar Code Programmer to the control/communicator.
2. Advance the programmer's display until the appropriate product handler's name appears. (*..8112Assign.x#..* or *..8112Cards.x#..*)
3. Scan the **ENTER** bar code. The display changes to show the "New File" prompt for the product handler: *8112S: New File* for 8112:Assign or *8112C: New File* for 8112:Cards.
4. Momentarily connect the D8112's restart terminal (32) to a common terminal (29).
5. Scan the **COPY PANEL** bar code. The display shows the prompt *WhichGroup?*. Scan the bar code for the number of the Group you want to copy. Scan the **ENTER** bar code.
6. The display momentarily shows *Copying 8112* and then changes to *8112S:* (for the 8112:Assign file) or *8112C:* (for the 8112:Cards file), to indicate that the file has been copied.

Reviewing the Copied File:

1. Scan the **ADVANCE** bar code to view the first User in the file. To view other Users you need to **ENTER** the User number while the programmer is displaying the *User #* prompt. (See section 9.5.2)
2. You may edit the file (do not change the Group number) and re-load it into the D8112, name and save the file, or scan the **EXIT** bar code to abandon the file. If you **ENTER**ed any User numbers, the programmer displays the prompt *# Enters Save?* when you scan the **EXIT** bar code, even if you have not changed any parameters.

9.5 Selecting Group and User Numbers for 8112:Assign and 8112:Cards

The first program item in the 8112:Assign and the 8112:Cards Product Handler Program is *Group 1*. This prompt is used to select the Group. Each group contains 32 User numbers.* The User numbers which can be programmed in each group are shown in Table 4.

Table 4

Group 1: Users 001 through 031	Group 2: Users 032 through 063	Group 3: Users 064 through 095	Group 4: Users 096 through 127
Group 5: Users 128 through 159	Group 6: Users 160 through 191	Group 7: Users 192 through 223	Group 8: Users 224 through 255

* The 8112:Cards Product Handler Program is used to program the D8112A to identify the serial number in the D8230, D8240, and D8235 Cards as "User" numbers.

9.5.1 To Select the Group Number:

1. ADVANCE the programmer's display to *Group 1*.
2. Scan the bar code for the appropriate Group (1, 2, 3, 4, 5, 6, 7, or 8), then scan the **ENTER** bar code.
3. The display changes to *User #*. The number sign (#) in this example represents the first User number for the Group you selected in step 2. (e.g: If you selected Group 3, the number is 64.)

9.5.2 To Select the User Number:

1. Determine the User number you wish to edit (e.g: User 77). Find the Group containing the User number (see Table 4, above).
2. Enter the Group number (e.g: Group 3) as described in section 9.5.1.
3. When the display shows *User 64*, scan the **CLEAR** bar code.
4. Scan the bar code(s) for the number of the User you wish to edit (e.g: 077). Scan the **ENTER** bar code. The first program item used to program parameters for the User appears in the programmer's display:

In the 8112:Assign program, the display changes to show *U77DoorA*.
See Section 10 to continue programming the 8112:Assign file.

In the 8112:Cards program, the display changes to show *U77Type Ø*.
See Section 11 to continue programming the 8112:Cards file.

5. When you have finished programming the User's information scan the **ENTER** or **ADVANCE** bar code until the *User #* prompt appears in the display.
6. If you need to program other Users in this Group, repeat steps 4 and 5 until all Users in the Group have been programmed.
7. When you need to program Users not found in the Group you are currently editing, you should **SAVE and EXIT** the file you have just edited, then **ADVANCE** from the title prompt to the "New File" prompt where you can create a file for another Group of Users.

IMPORTANT: The Group number should not be changed after entries have been made in the file.

10. The 8112:Assign Program Entry Guide

The characteristics of up to seven authorization levels are programmed in the 8112:Access Product Handler Program. Each authorization level can be programmed to: 1) allow or deny access if the panel is Master armed, 2) allow or deny access if the panel is Perimeter armed, and 3) disarm the panel, or disarm only the interior zones when a User with the proper authorization level enters. (See Part I of this manual, section 7 for more details.)

The authorization levels (1 through 7) programmed in 8112:Access are used in the 8112:Assign Product Handler to assign the User's authorization level for each of the doors (A, B, C, and D) in the access control system. (For information about setting door addresses, see the operation and installation instructions for the D8220 Insert Reader and/or the D8225 Proximity Reader System.)

10.1 Getting Around in the 8112:Assign Product Handler Program

1. ADVANCE the D5100 programmer's display to `..8112Assign.x#..`. Scan the ENTER bar code.
2. When the display shows `8112S: New File` scan the ENTER bar code.
3. The display now shows `8112S:`. The blank space is provided for a file title. If you plan on saving this file, see section "9.2 Naming 8112:Assign and 8112:Cards Files." If you don't wish to save the file scan the ENTER or the ADVANCE bar code to skip over the file title.
4. The display now shows `Group 1`. This is the first item of the 8112:Assign program. To continue programming, see section "10.2 The Program Items of the 8112:Assign Product Handler Program." The diagram below shows an overview of the 8112:Assign Product Handler Program.

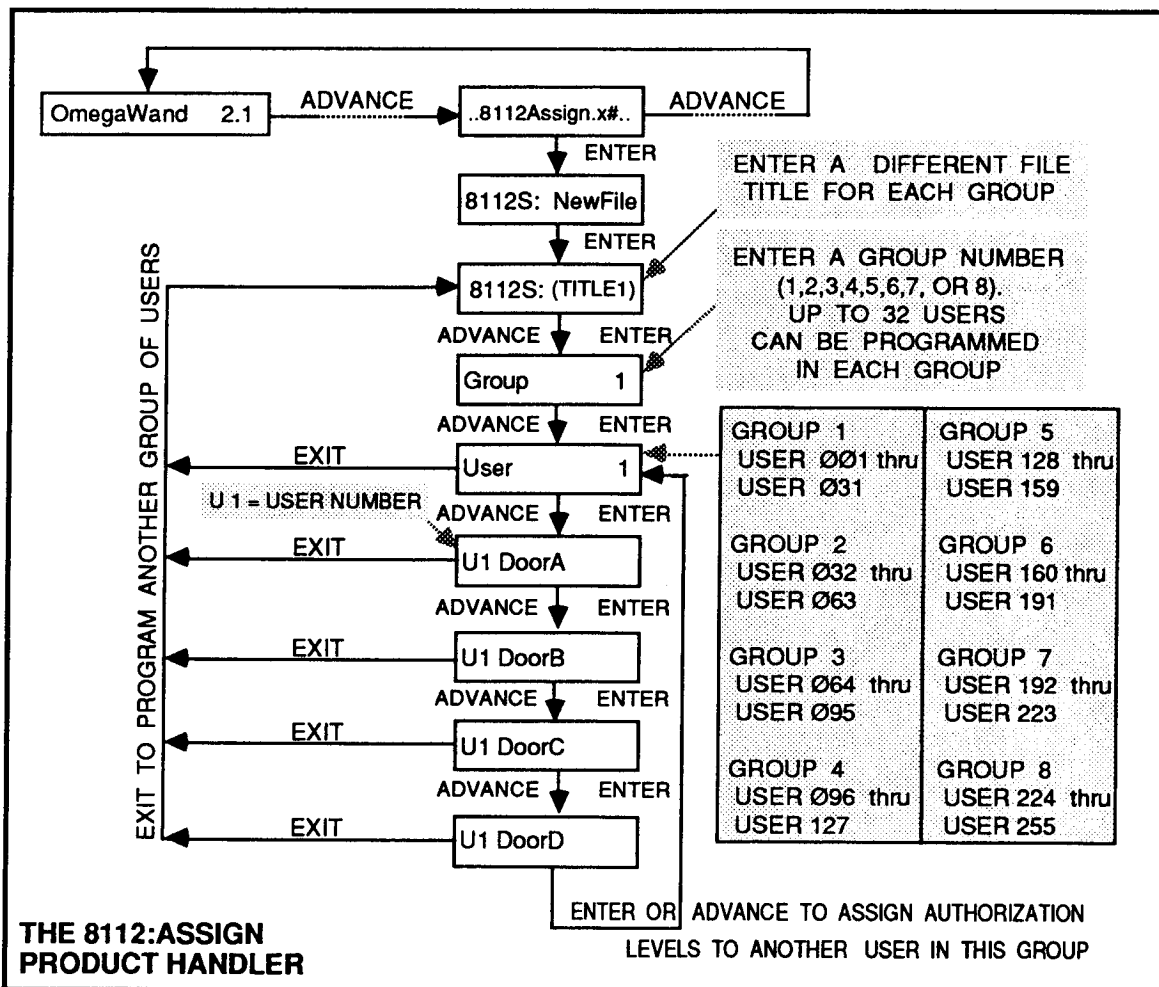

10.2 The Program Items of the 8112:Assign Product Handler

Prompt & Default	Selections	Description
Group 1	1 through 8	<p>Enter the Group number you wish to program.</p> <p>IMPORTANT: The Group number should <u>not</u> be changed after entries have been made in the file.</p> <p>When you need to program Users not found in the Group you are currently editing, you should SAVE and EXIT the file you have just edited, then ADVANCE from the title prompt to the "New File" prompt where you can create a file for another Group of Users.</p>
User 1	See Table 1	<p>Enter a User number appropriate to the Group number you are editing. To change this program item entry, either scan the CLEAR bar code before making the entry, or, enter three digits (e.g: to enter User number 23, scan the 0, the 2, and the 3 bar codes).</p> <p>Note: If you enter a User number which is outside of the range of the Group being programmed, the programmer "tweedles" to indicate the invalid entry.</p>
U###DoorA	1 through 7 or Blank	<p>Enter this User's authorization level for Door A. Blank entry means the User is denied access at this door.</p>
U###DoorB	1 through 7 or Blank	<p>Enter this User's authorization level for Door B. Blank entry means the User is denied access at this door.</p>
U###DoorC	1 through 7 or Blank	<p>Enter this User's authorization level for Door C. Blank entry means the User is denied access at this door.</p>
U###DoorD	1 through 7 or Blank	<p>Enter this User's authorization level for Door D. Blank entry means the User is denied access at this door.</p>

11. The 8112:Cards Program Entry Guide

The 8112:Cards Product Handler Program is used to program the D8112A to identify the serial numbers in the D8230-25 Magnetic Stripe Cards, D8240-25 Magnetic Stripe Cards, and D8235-10 Proximity Cards as "User" numbers.

11.1 Getting Around in the 8112:Cards Product Handler Program

1. ADVANCE the D5100 programmer's display to `..8112Cards.x#..`. Scan the **ENTER** bar code.
2. When the display shows `8112C: New File` scan the **ENTER** bar code.
3. The display now shows `8112C:`. The blank space is provided for a file title. If you plan on saving this file, see section "9.2 Naming 8112:Assign and 8112:Cards Files." If you don't wish to save the file scan the **ENTER** or the **ADVANCE** bar code to skip over the file title.
4. The display now shows `Group 1`. This is the first item of the 8112:Cards program. To continue programming, see section "11.2 The Program Items of the 8112:Cards Product Handler Program." The diagram below shows an overview of the 8112:Cards Product Handler Program.

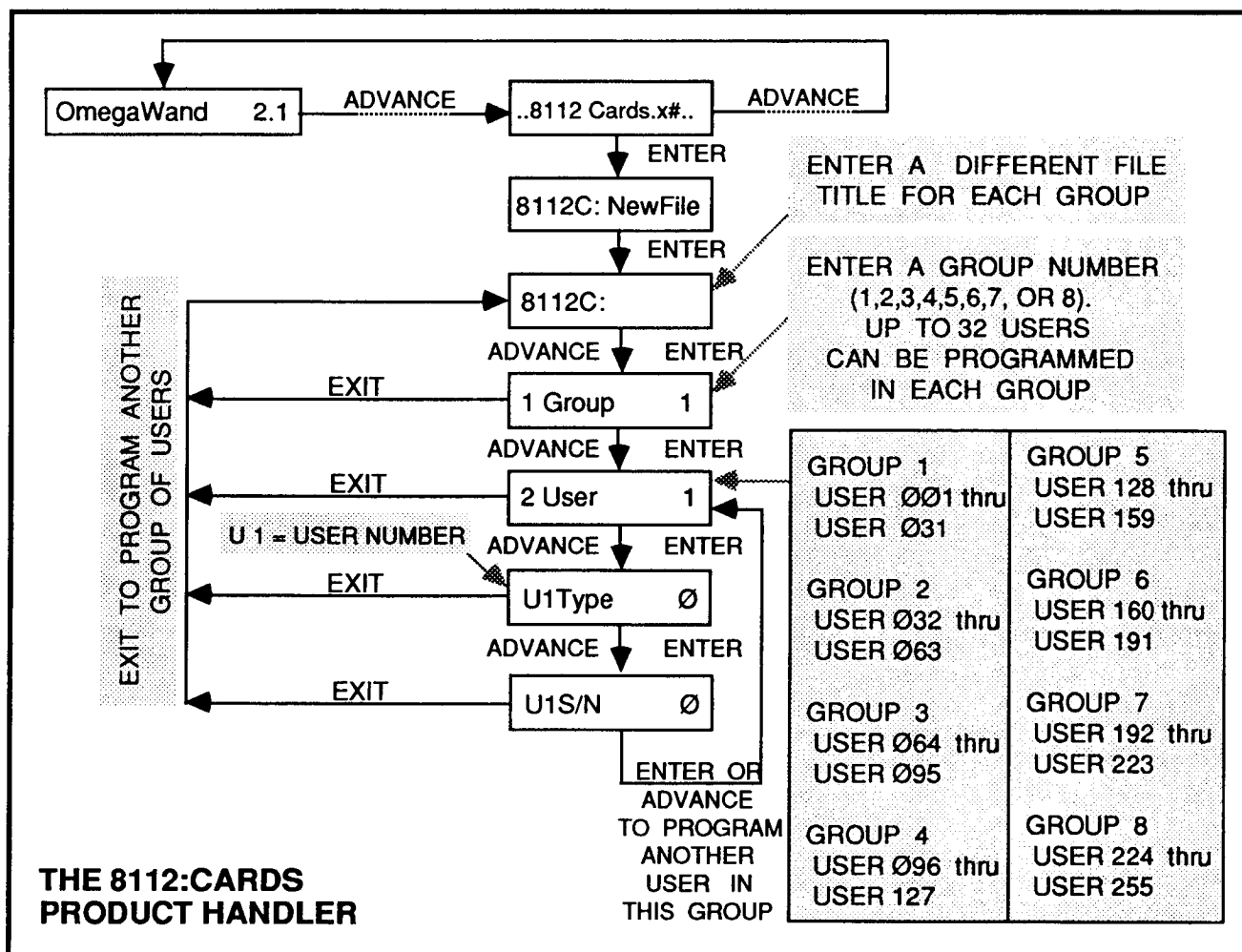

11.2 The Program Items of the 8112:Cards Product Handler

Prompt & Default	Selections	Description
1 Group 1	1 through 8	<p>Enter the Group number you wish to program.</p> <p>IMPORTANT: The Group number should <u>not</u> be changed after entries have been made in the file.</p> <p>When you need to program Users not found in the Group you are currently editing, you should SAVE and EXIT the file you have just edited, then ADVANCE from the title prompt to the "New File" prompt where you can create a file for another Group of Users.</p>
2 User 1	See Table 1	<p>Enter a User number appropriate to the Group number you are editing. To change this program item entry, either scan the CLEAR bar code before making the entry, or, enter three digits (e.g: to enter User number 23, scan the Ø, the 2, and the 3 bar codes).</p> <p>Note: If you enter a User number which is outside of the range of the Group being programmed, the programmer "tweedles" to indicate the invalid entry.</p>
U###Type Ø	Ø thru 4096 (Blank = Ø)	<p>Enter the type of card assigned to this User.</p> <p>Enter Ø, or leave blank for Radionics D8230-25 and D8240-25 Magnetic Stripe Cards, and D8235-10 Proximity Cards with serial numbers 1,048,575 AND LOWER.</p> <p>ENTER "1" For Radionics D8235-10 Proximity Cards with serial numbers HIGHER THAN 1,048,575 (See Note below).</p> <p>For cards having a serial number with a letter prefix, enter the appropriate number (e.g.: "A" = 1, "B" = 2, "C" = 3, etc.).</p>
U###S/N Ø	Ø thru 1,048,575 (Blank = Ø)	<p>Enter the card's Serial Number as it is imprinted on the back of the card. For cards with a letter prefix, enter only the numbers printed on the card, do not enter the letter prefix.</p>

NOTE for D8235-10 Proximity Cards with serial numbers HIGHER THAN 1,048,575:
 Enter a "1" in **U###Type** when the serial number exceeds 1,048,575. Enter the serial number as it appears on the card. The number appearing in the display when you *later* review the file will NOT be the same as the serial number you entered – this is normal. Explanation: When a number larger than 1,048,575 is entered, the D5100 *automatically* subtracts 1,048,576 from that number to arrive at the number which appears in the display when the file is later reviewed. e.g.: when 1,049,123 is entered
 1,048,576 is subtracted
 547 is the result in the display

NOTE: Another way to program User's cards into the D8112A is to use COMMAND 53 at the Alpha II Command Center. See the *8112:AUX Program Entry Guide*, Cmd5's Subhandler Program, and the *Alpha II Command Center User's Guide* for instructions. No special procedures are required for adding cards with serial numbers larger than 1,048,575. When such a card is added using command 53, and the Cards program is later **copied** using the D9301 R.A.M., a "1" appears in the Type field, and the serial number is displayed as the **result** of the subtraction shown above.